

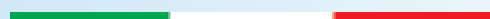

VENTILCONVETTORE A CASSETTA
WATER CASSETTE FAN COIL UNIT
Mod. **PS-CL PS-CLE**

 **PST**
clima

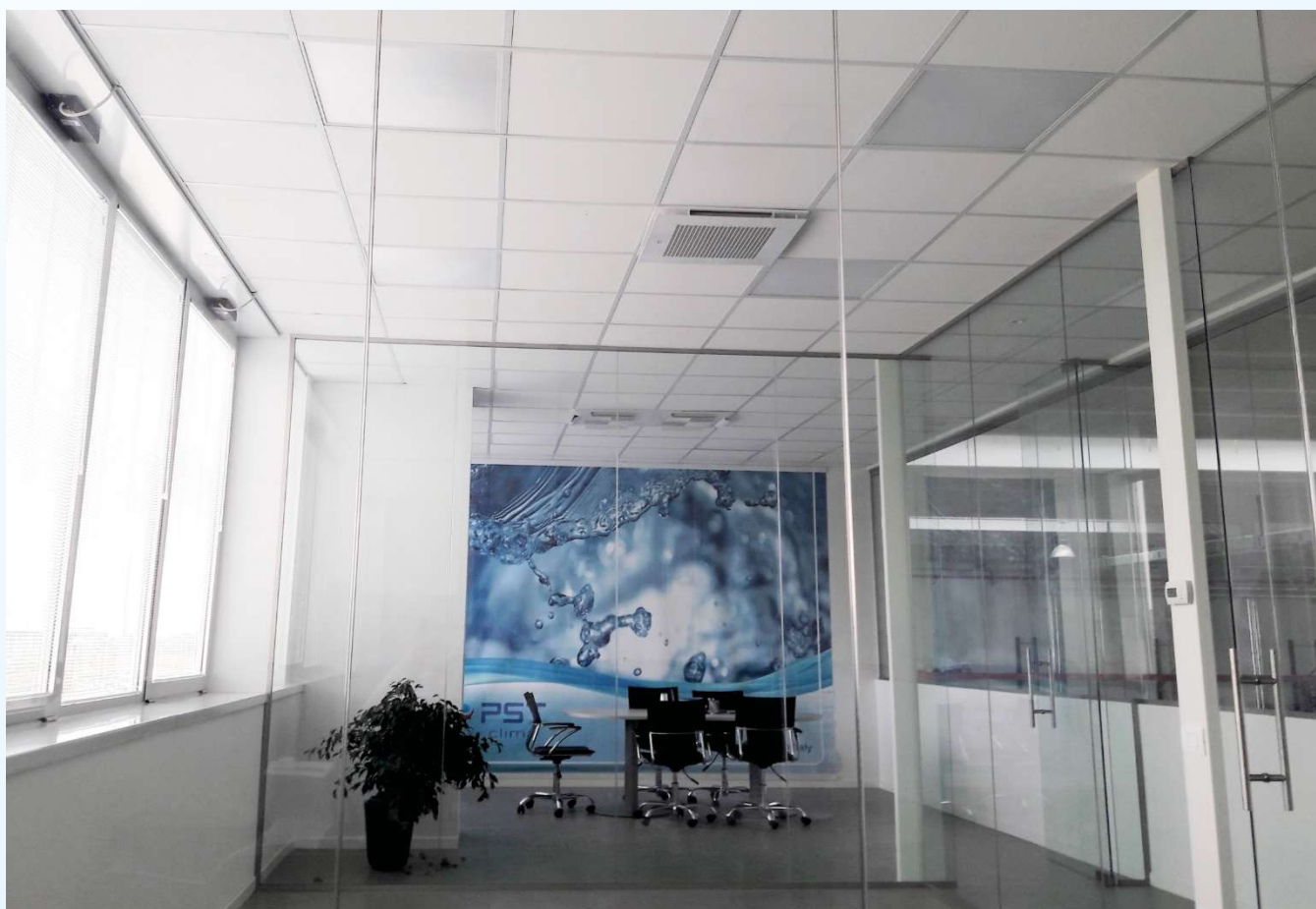



Le unità idroniche a soffitto **PS-CL** con il loro moderno design, la flessibilità di regolazione, la semplicità di manutenzione e la massima silenziosità rappresentano il risultato di accurate analisi per l'ottenimento di un articolo innovativo, adattabile a qualsiasi ambiente ed arredamento, che risponde alle molteplici esigenze estetiche e funzionali. Le dimensioni si adattano perfettamente alla modularità dei pannelli per controsoffitti. Disponibile NUOVA versione con batteria a 4 Ranghi, che permette di raggiungere rese molto più performanti, aumentando la capacità di un 20%.

Proponiamo inoltre una nuova versione di cassetta: **PS-CLH** caratterizzata da uno speciale sviluppo verticale dello chassis e progettata in modo da permettere lo scarico condensa in modo naturale, evitando così l'installazione di una pompa estrazione condensa. Queste unità sono adatte per l'installazione in ambienti in cui sono richiesti particolari requisiti igienico-sanitari, dove è necessario facilitare e ridurre gli interventi di manutenzione o dove è richiesto un valore contenuto di emissioni sonore (ospedali, case di riposo, scuole, biblioteche..)

PS-CL ceiling chilled water cassette units, thanks to their modern design, setting flexibility, easy maintenance and maximum silence represent the result of accurate researches in order to achieve an innovative product, perfect for every surrounding and interior design. They respond to the multiple aesthetic and functional needs. The dimensions fit in the false-ceiling panels modularity. NEW version with 4 Rows coil available, which allows to obtain more efficiency, by increasing the capacities up to 20% more.

We also propose a new version of hydronic cassette unit: the **PS-CLH** characterized by a special vertical extension of the chassis and projected in such a way as to allow condensation to drain naturally, by avoiding the installation of a condensate pump. These units are suitable for the installation in environments where particular hygienic-sanitary requirements are necessary, where a low noise level is required and where it is important to simplify the maintenance procedures (hospitals, nursing, school, libraries..)

+ PLUS



Basso consumo elettrico
Low electricity consumption



Silenzioso
Low noise



Alta efficienza
High efficiency



Facile manutenzione ed installazione
Easy maintenance and installation

COMPONENTI COMPONENTS

PS-CL / PS-CLE

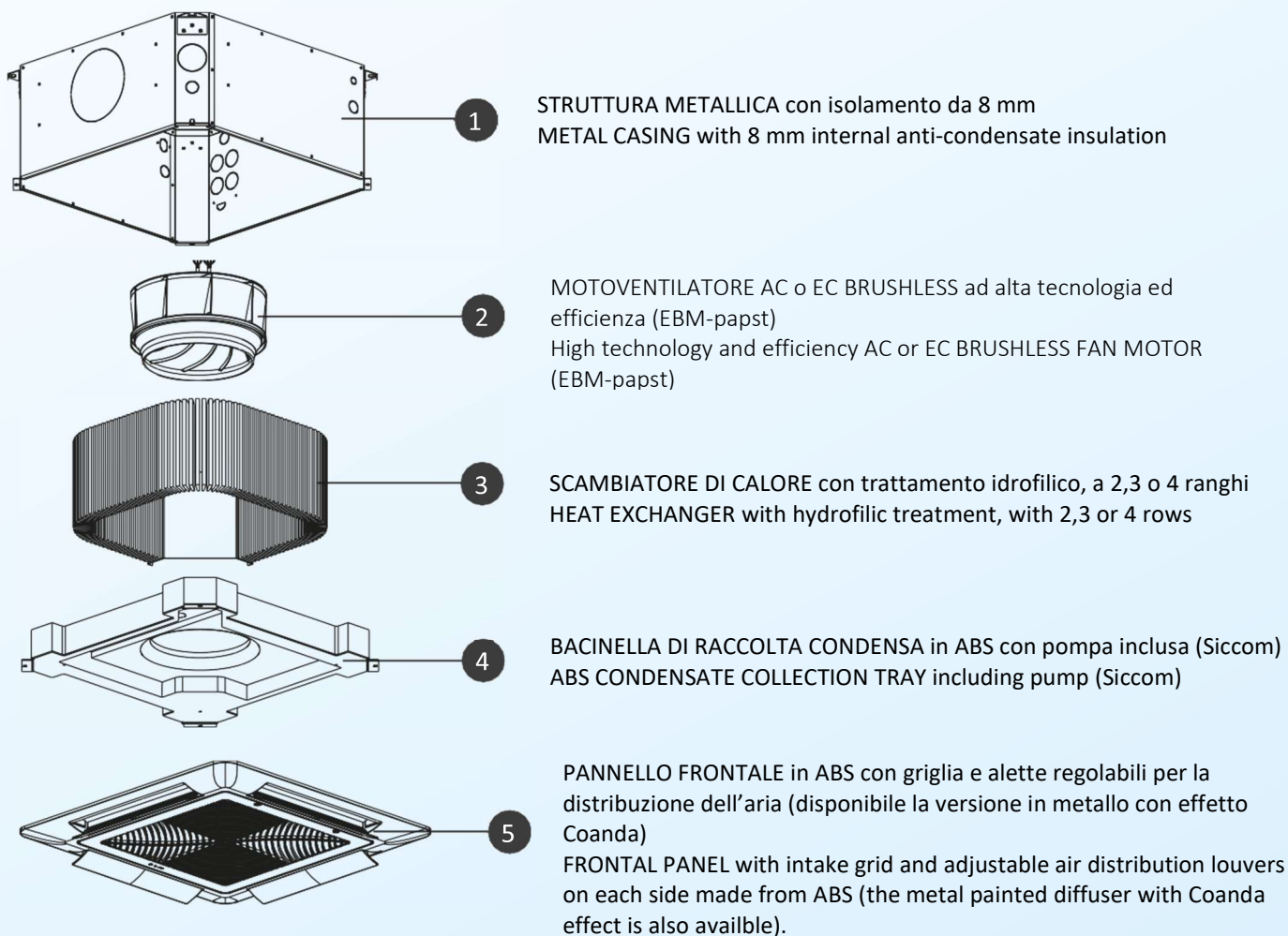

ACCESSORI ACCESSORIES



Cod. TER.ANA



Cod. TER.EC.DIG



Cod. TEL



Cod. TER.BUS



Cod. VAL.2V.12



Cod. VAL.3V.12



Cod. VAL.SFE.12



Cod. EST 1/2

DATI TECNICI VERSIONE AC – TECHNICAL DETAILS AC VERSION

PS-CL	2TUBI/PIPES	050/2R	070/2R	080/3R	090/3R	080/4R	090/4R	100/3R	120/3R	150/3R	150/4R
Capacità totale freddo ¹ Total cooling capacity	KW (max)	2,39	3,51	5,06	5,72	6,16	6,84	7,21	8,83	10,85	12,99
	KW (med)	1,56	2,47	3,29	4,13	3,99	4,87	5,99	7,26	8,21	9,63
	KW (min)	1,45	1,48	2,98	3,04	3,64	3,61	5,55	6,01	6,47	7,52
Capacità sensib. freddo ¹ Sensible cooling capacity	KW (max)	1,79	2,46	3,38	3,78	4,07	4,57	4,67	5,74	6,98	8,24
	KW (med)	1,48	1,82	2,25	2,77	2,61	3,23	3,90	4,75	5,31	6,14
	KW (min)	1,31	1,32	2,06	2,08	2,37	2,36	3,62	3,96	4,22	4,79
Portata acqua ¹ Water flow	l/h (H)	410,07	602,42	868,82	981,66	1057,46	1173,25	1236,76	1515,59	1861,6	2228,13
Perdita di carico ¹ Pressure drop	kPa	10	17	14	18	23	27	32,7	28	31	34
Capacità caldo ² Heating capacity	KW (max)	3,41	4,78	6,25	7,03	7,15	8,06	8,43	10,46	12,72	14,22
	KW (med)	2,72	3,47	4,06	5,04	4,50	5,62	6,95	8,53	9,49	10,38
	KW (min)	2,42	2,45	3,69	3,73	4,06	4,07	6,42	7,03	7,42	7,98
Portata acqua ² Water flow	l/h (H)	410,07	602,47	868,82	981,66	1057,46	1173,25	1236,76	1515,59	1861,60	2228,13
Perdita di carico ² Pressure drop	kPa	9	15	13	17	21	25	30	26	28	31
Portata aria Air flow	m ³ /h(max)	500	750	800	910	800	910	1000	1270	1550	1550
	m ³ /h(med)	400	500	480	610	480	610	800	1000	1100	1100
	m ³ /h (min)	340	340	430	430	430	430	730	800	830	830
Livello pressione sonora Sound pressure level	dB (A) (H/M/L)	39/32/23	44/36/24	45/37/31	47/41/32	45/37/31	47/41/32	41/32/26	47/41/32	51/45/33	51/45/33
Alimentazione Power supply	V/Ph/Hz	210-230/1/50-60									
Potenza assorbita Absorbed power	W (max)	35	63	75	78	75	78	85	110	150	150
Corrente assorbita Absorbed current	A (max)	0,16	0,28	0,35	0,34	0,35	0,34	0,39	0,58	0,67	0,67
Connessioni idriche Water connections	Nr. x "	2 x 3/4" F									
Dimensioni unità/Unit sizes Dimen. pannello/ Panel sizes	mm (L-P-H)	570x570x250 (620x620x30)						1170x570x250 (1220x620x30)			
Peso totale/Total weight	Kg	18	18	19	19	19	19	38	38	38	38

PS-CL	4TUBI/PIPES	054/2R+1	084/2R+1	094/2R+1	094/3R+1	124/2R+1	154/2R+1	154/3R+1
Capacità totale freddo ¹ Total cooling capacity	KW (max)	2,97	4,08	4,56	5,72	6,93	8,59	10,82
	KW (med)	2,23	2,80	3,38	4,13	5,80	6,66	8,21
	KW (min)	2,01	2,58	2,57	3,04	4,90	5,38	6,50
Capacità sensib. freddo ¹ Sensible cooling capacity	KW (max)	1,95	2,63	3,00	3,78	4,47	5,48	6,91
	KW (med)	1,47	1,82	2,24	2,77	3,76	4,27	5,26
	KW (min)	1,33	1,67	1,72	2,08	3,18	3,46	4,19
Portata acqua ¹ Water flow	l/h (H)	510,02	700,32	782,96	981,66	1189,10	1473,64	1856,28
Perdita di carico ¹ Pressure drop	kPa	12	18	20	25	23	28	29
Capacità caldo ² Heating capacity	KW (max)	4,77	6,27	6,84	6,84	10,26	12,17	12,17
	KW (med)	3,66	4,39	5,19	5,19	8,69	9,06	9,60
	KW (min)	3,31	4,06	4,06	4,06	7,43	7,87	7,87
Portata acqua ² Water flow	l/h (H)	419,34	550,37	600,77	600,77	901,3	1068,56	1068,56
Perdita di carico ² Pressure drop	kPa	11	19	22	22	16	19	16
Portata aria Air flow	m ³ /h(max)	570	800	910	910	1270	1550	1550
	m ³ /h(med)	390	480	610	610	1000	1100	1100
	m ³ /h (min)	340	430	430	430	800	830	830
Livello pressione sonora Sound pressure level	dB (A) (H/M/L)	39/32/23	45/37/31	47/41/32	47/41/32	47/41/32	51/45/33	51/45/33
Alimentazione Power supply	V/Ph/Hz	210-230/1/50-60						
Potenza assorbita Absorbed power	W (max)	35	75	78	78	110	150	150
Corrente assorbita Absorbed current	A (max)	0,19	0,35	0,34	0,34	0,58	0,67	0,67
Connessioni idriche Water connections	Nr. x "	4 x 3/4" F						
Dimensioni unità/Unit sizes Dimen. pannello/ Panel sizes	mm (L-P-H)	570x570x250 (620x620x30)				1170x570x250 (1220x620x30)		
Peso totale/Total weight	Kg	19,5	19,5	19,5	19,5	39	39	39

Reference conditions:

- 1: water temperature 7/12°C, air temperature 27°C d.b. -19° C w.b.
- 2: water temperature IN 50°C, air temperature 20°C
- 3: sound pressure level measured in closed room with 0,4s reverberation time, at 1mt distance
- *: absorbed power and current tested with digital-electronic counter mod. IME CONTO D2
- 4: pipes version: water temperature IN 70°C, OUT 60°C, air temperature 20°C

Functioning limits:

- max temperature IN water 80°C
- max working water pressure 10 bar

Condizioni di riferimento

- 1: temperatura acqua 7/12°C, temperatura aria 27°C b.s. 19°C b.u.
- 2: temperatura acqua IN 50°C, temperatura aria 20°C
- 3: livello di pressione sonora misurata in ambiente chiuso con tempo di riverberazione pari a 0,4s, a 1 m di distanza
- *: potenza e corrente assorbita misurate con contatore digitale elettrico mod. IME CONTO D2
- 4: Versione 4 tubi: temperatura acqua IN 70°C, OUT 60°C, temperatura dell'aria 20°C

Limiti di funzionamento:

- temperatura massima IN acqua 80°C
- pressione massima di lavoro dell'acqua 10 bar

PS-CLE	2TUBI/PIPES	070/2R	090/3R	090/4R	150/3R	150/4R
Capacità totale freddo ¹ Total cooling capacity	KW (max)	4,32	6,07	7,29	11,24	13,49
	KW (med)	2,88	4,01	4,74	9,77	11,60
	KW (min)	1,27	1,89	2,17	6,41	7,44
Capacità sensib. freddo ¹ Sensible cooling capacity	KW (max)	2,99	4,01	4,86	7,22	8,56
	KW (med)	2,06	2,69	3,14	6,29	7,38
	KW (min)	1,04	1,28	1,40	4,17	4,73
Portata acqua ¹ Water flow	l/h (H)	741,75	1041,15	1251,27	1928,31	2314,19
Perdita di carico ¹ Pressure drop	kPa	18	17	29	28	35
Capacità caldo ² Heating capacity	KW (max)	5,85	7,47	8,60	13,20	14,80
	KW (med)	3,96	4,90	5,46	11,39	12,63
	KW (min)	1,94	2,29	2,43	7,34	7,88
Portata acqua ² Water flow	l/h (H)	741,75	1041,15	1251,27	1928,31	2314,19
Perdita di carico ² Pressure drop	kPa	16	15	23	23	32
Portata aria Air flow	m ³ /h(max)	980	980	980	1620	1620
	m ³ /h(med)	590	590	590	1360	1360
	m ³ /h (min)	250	250	250	820	820
Livello pressione sonora Sound pressure level	dB (A) (H/M/L)	48/34/18	48/34/18	48/34/18	51/44/26	51/44/26
Alimentazione Power supply	V/Ph/Hz	210-230/1/50-60				
Potenza assorbita Absorbed power	W (max)	41	45	45	85	85
Corrente assorbita Absorbed current	A (max)	0,36	0,42	0,42	0,55	0,55
Connessioni idriche Water connections	Nr. x "	2 x 3/4"F				
Dimensioni unità/Unit sizes Dimen. pannello/ Panel sizes	mm (L-P-H)	570x570x250 (620x620x30)			1170x570x250 (1220x620x30)	
Peso totale/Total weight	Kg	18	19	19	38	38

PS-CLE	4TUBI/PIPES	094/2R+1	094/3R+1	154/2R+1	154/3R+1
Capacità totale freddo ¹ Total cooling capacity	KW (max)	4,82	6,39	8,87	11,20
	KW (med)	3,3	4,26	7,80	9,75
	KW (min)	1,58	2,05	5,33	6,43
Capacità sensib. freddo ¹ Sensible cooling capacity	KW (max)	3,16	4,11	5,66	7,15
	KW (med)	2,19	2,76	4,99	6,23
	KW (min)	1,12	1,35	3,43	4,14
Portata acqua ¹ Water flow	l/h (H)	826,76	1095,85	1521,64	1922,55
Perdita di carico ¹ Pressure drop	kPa	18	17	33	28
Capacità caldo ² Heating capacity	KW (max)	7,19	7,19	12,54	12,54
	KW (med)	5,08	5,08	11,12	11,12
	KW (min)	2,73	2,73	7,80	7,80
Portata acqua ² Water flow	l/h (H)	631,63	631,63	1101,24	1101,24
Perdita di carico ² Pressure drop	kPa	23	23	38	38
Portata aria Air flow	m ³ /h(max)	980	980	1620	1620
	m ³ /h(med)	590	590	1360	1360
	m ³ /h (min)	250	250	820	820
Livello pressione sonora Sound pressure level	dB (A) (H/M/L)	48/34/18	48/34/18	51/44/26	51/44/26
Alimentazione Power supply	V/Ph/Hz	210-230/1/50-60			
Potenza assorbita Absorbed power	W (max)	45	45	85	85
Corrente assorbita Absorbed current	A (max)	0,42	0,42	0,55	0,55
Connessioni idriche Water connections	Nr. x "	4 x 3/4"F			
Dimensioni unità/Unit sizes Dimen. pannello/ Panel sizes	mm (L-P-H)	570x570x250 (620x620x30)		1170x570x250 (1220x620x30)	
Peso totale/Total weight	Kg	19,5	19,5	39	39

Reference conditions:

- 1: water temperature 7/12°C, air temperature 27°C d.b. -19° C w.b.
- 2: water temperature IN 50°C, air temperature 20°C
- 3: sound pressure level measured in closed room with 0,4s reverberation time, at 1m distance
- *: absorbed power and current tested with digital-electronic counter mod. IME CONTO D2
- 4: pipes version: water temperature IN 70°C, OUT 60°C, air temperature 20°C

Functioning limits:

- max temperature IN water 80°C
- max working water pressure 10 bar

Condizioni di riferimento

- 1: temperatura acqua 7/12°C, temperatura aria 27°C b.s. 19°C b.u.
- 2: temperatura acqua IN 50°C, temperatura aria 20°C
- 3: livello di pressione sonora misurata in ambiente chiuso con tempo di riverberazione pari a 0,4s, a 1 m di distanza
- *: potenza e corrente assorbita misurate con contatore digitale elettrico mod. IME CONTO D2
- 4: Versione 4 tubi: temperatura acqua IN 70° C, OUT 60°C, temperatura dell'aria 20°C

Limiti di funzionamento:

- temperatura massima IN acqua 80°C
- pressione massima di lavoro dell'acqua 10 bar

DIMENSIONI DIMENSIONS

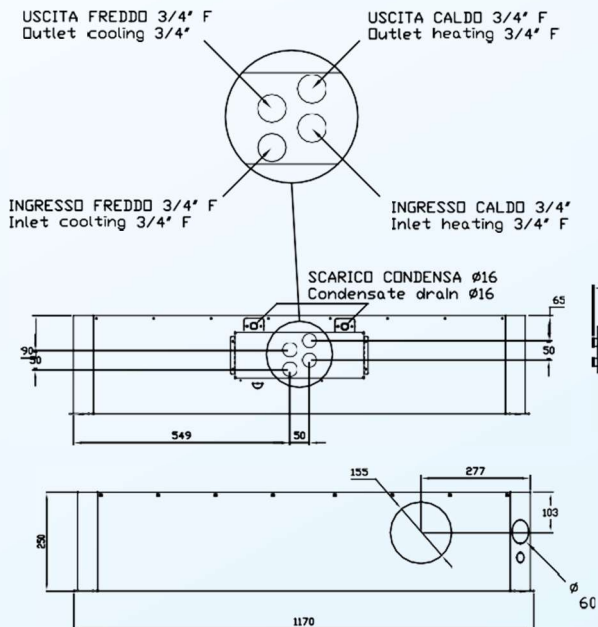
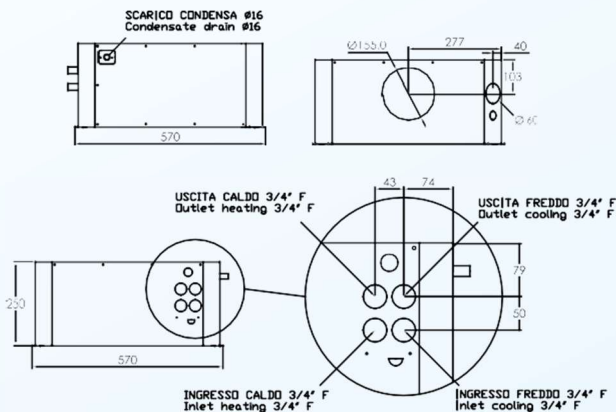

DIMENSIONI-DIMENSIONS

UNITA' IDRONICA mod. PS-CL
versione singola 570x570x250 mm
HYDRONIC CASSETTE UNIT mod. PS-CL
single version 570x570x250 mm

DIMENSIONI-DIMENSIONS

UNITA' IDRONICA mod. PS-CL
versione doppia 1170x570x250 mm
HYDRONIC CASSETTE UNIT mod. PS-CL
double version 1170x570x250 mm

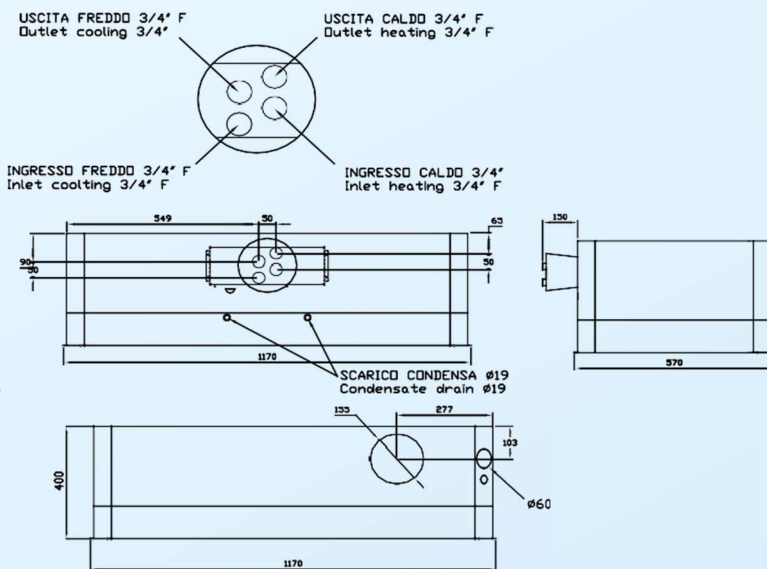
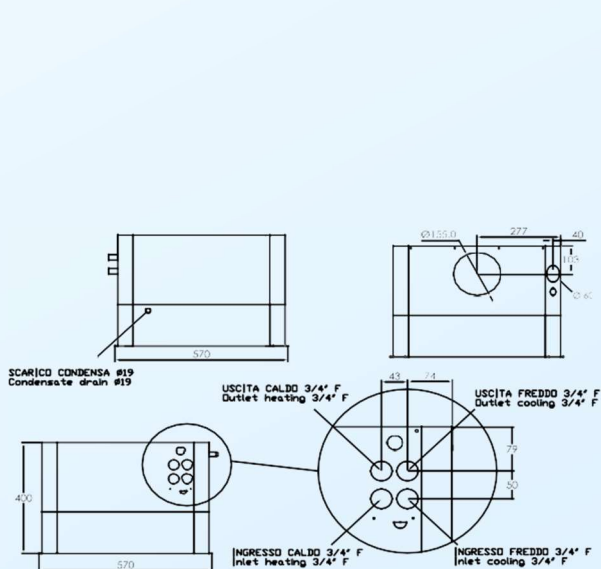

DIMENSIONI-DIMENSIONS

UNITA' IDRONICA rialzata mod. PS-CLH
versione singola 570x570x400 mm
HYDRONIC CASSETTE UNIT with higher frame mod. PS-CLH
single version 570x570x400 mm

DIMENSIONI-DIMENSIONS

UNITA' IDRONICA rialzata mod. PS-CLH
versione doppia 1170x570x400 mm
HYDRONIC CASSETTE UNIT with higher frame mod. PS-CLH
double version 1170x570x400 mm

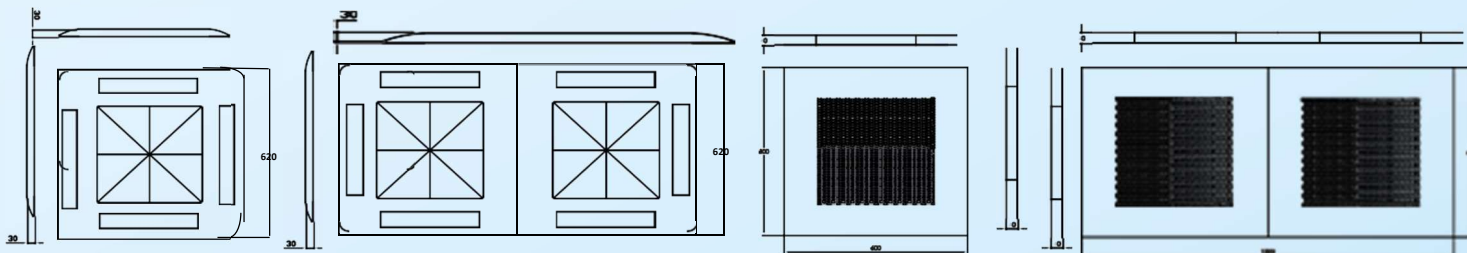

DIMENSIONI-DIMENSIONS

PANNELLO FRONTALE IN ABS
versione singola 620x620x30 mm
ABS FRONT PANEL
single version 620x620x30 mm

DIMENSIONI-DIMENSIONS

PANNELLO FRONTALE IN ABS
versione doppia 1220x620x30 mm
ABS FRONT PANEL
double version 1220x620x30 mm

DIMENSIONI-DIMENSIONS

PANNELLO FRONTALE METALLICO (COANDA)
versione singola 600x600x40 mm
METALLIC (COANDA) FRONT PANEL
single version 600x600x40 mm

DIMENSIONI-DIMENSIONS

PANNELLO FRONTALE METALLICO (COANDA)
versione doppia 1200x600x40 mm
METALLIC (COANDA) FRONT PANEL
double version 1200x600x40 mm

VERSIONI DISPONIBILI

AVAILABLE VERSIONS



Mod. PS-CL / PS-CLE

UNITA' IDRONICA A SOFFITTO con pannello ABS-versione singola
CEILING WATER CASSETTE UNIT with ABS air diffuser- single version



Mod. PS-CL / PS-CLE

UNITA' IDRONICA A SOFFITTO con pannello ABS-versione doppia
CEILING WATER CASSETTE UNIT with ABS air diffuser- double version



Mod. PS-CLM / PS-CLEM

UNITA' IDRONICA A SOFFITTO con pannello in metallo (effetto Coanda)
versione singola
CEILING WATER CASSETTE UNIT with metal air diffuser (Coanda effect)
single version



Mod. PS-CLM / PS-CLEM

UNITA' IDRONICA A SOFFITTO con pannello in metallo (effetto Coanda)
versione doppia
CEILING WATER CASSETTE UNIT with metal air diffuser (Coanda effect)
double version



Mod. PS-CLH / PS-CLEH

UNITA' IDRONICA A SOFFITTO rialzata (configurazione senza pompa
condensa) versione singola
CEILING WATER CASSETTE UNIT with higher frame (configuration
without condensate pump) single version



Mod. PS-CLH / PS-CLEH

UNITA' IDRONICA A SOFFITTO rialzata (configurazione senza pompa
condensa) versione doppia
CEILING WATER CASSETTE UNIT with higher frame (configuration
without condensate pump) double version



Mod. PS-CLC / PS-CLCE

UNITA' IDRONICA A SOFFITTO con mantello metallico per installazione
esterna (soluzione per utilizzo unità dove non è presente un contro soffitto)
Disponibile sia per la versione singola che per quella doppia.
CEILING WATER CASSETTE UNIT with metal covering for external installation
(solution for use in units where there is no false ceiling)
Available for both single and double version.

Mod. PS-CLB / PS-CLEB

UNITA' IDRONICA A SOFFITTO per installazione ad altezze elevate
CEILING WATER CASSETTE UNIT suitable for installation over high ceiling

PST Clima Srl

Via Pietro Candiano, 8
36016 Thiene (VI) - ITALY

Tel. +39 0445 540348

vendite@pstclima.it
export@pstclima.it
www.pstclima.it



The company producer reserves the right to modify dimensions and technical details at any time without any notice

L'azienda produttrice si riserva la facoltà di modificare dimensioni e dati tecnici senza preavviso e in qualsiasi momento.

 **Made in Italy**